



Daytona



BP-12A
12,000 LBS 2-POST
FLOORPLATE LIFT



BP-12A

Note: Product may vary slightly from image shown

Features

- 12,000 lbs lifting capacity
- Automatic safety locks, with single point lock release
- High polymer polyethylene wear resistant slide blocks
- Dual chain drive Hydraulic cylinders
- Screw up pads
- Height limit switch
- Rubber door guards
- Powder coat finish for durability
- Three stage front arms
- Truck adapters standard

Daytona

BP-12A

12,000 LBS 2-POST FLOORPLATE LIFT

Specifications

Power - 240V 3HP 13A PH1 60Hz

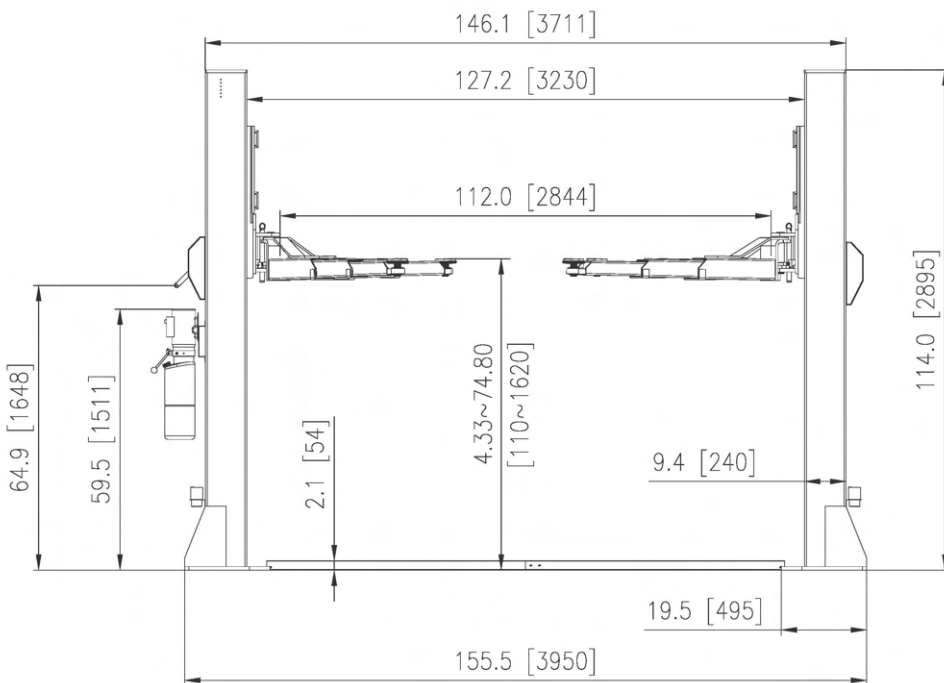

DIMENSIONS, COLOURS AND ITEMS ARE SUBJECT TO CHANGE WITHOUT PRIOR NOTICE DUE TO OUR CONTINUOUS IMPROVEMENT PROGRAM

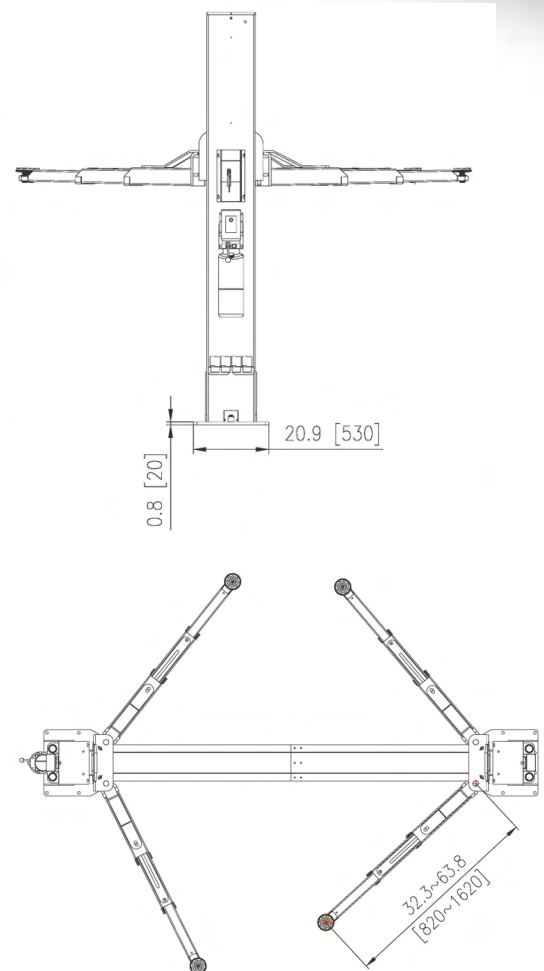

Shipping Dimensions: Lift 116" x 22" x 39" 2200lbs
Pump 31" x 12" x 11" 60lbs

720 W. Myers Blvd, Mascotte, FL 34753

407-325-4515 - Liftman53@Gmail.com

Florida Lift Experts